



**3.5inch Product Models**

Model No.	Unformatted[MB]	Capacity[byte]	Max LBA	Cylinder	Head	Sector
MFD35C-512MS(A00AT)	482	506,290,176	988,848	981	16	63
MFD35C-001GS(A00AT)	957	1,004,322,816	1,961,568	1946	16	63
MFD35C-002GS(A00AT)	1835	1,925,038,080	3,759,840	3730	16	63
MFD35C-004GS(A00AT)	3671	3,850,076,160	7,519,680	7,460	16	63
MFD35C-008GS(A00AT)	7343	7,700,668,416	15,040,368	14,921	16	63

## System Configuration

The drive in this series performs input and output operations designated from the SCSI host adaptor that behaves as an initiator. An example of the system configuration will be shown below.

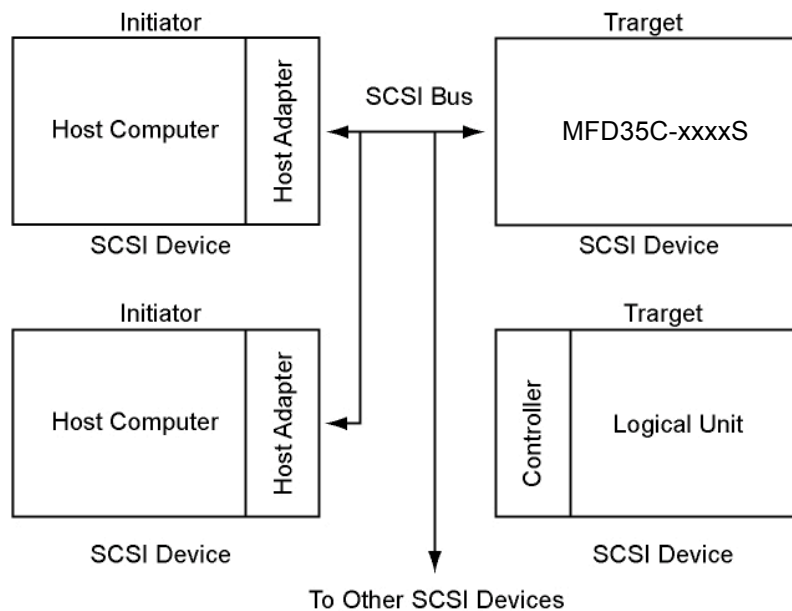

### (1) Structure of SCSI bus

A SCSI bus can link up to eight SCSI devices. A SCSI device behaving as an initiator and a SCSI device behaving as a target device can be combined arbitrarily.

### (2) Addressing of input/output devices

A specific device number (SCSI-ID) is assigned to each of SCSI devices. A device for input and output operations, which is on a SCSI device operating as a target or linked to the device, is accessed in units referred to as logical units, and each has its specific device number (LUN: logical unit number) assigned. An initiator designates SCSI-ID to select a single SCSI device operating as a target device, then designates LUN to select a device on the target device or linked thereto for an input and output operation. SCSI-ID and LUN are selectable within the following ranges.

- SCSI-ID: selectable within the range of #0 to #7 (select by the DIP switch on the conversion adaptor)
- LUN: #0 fixed

**Product Specification****Capacity**

482MB, 957MB, 1835MB, 3671MB, 7343MB (Unformatted)

**Transfer rate**

Asynchronous mode	5.0MByte/sec (Max.)
5MB/s Synchronous mode	5.0MByte/sec (Max.)
10MB/s Synchronous mode(FAST)	10.0MByte/sec (Max.)
20MB/s Synchronous mode(FAST-20)	20.0MByte/sec (Max.)

**Performance**

Transfer rate	20.0MByte/sec (Max.) [Burst data transfer rate]
Read speed [Fast-20(Ultra SCSI)]	17.0MByte/sec(Max.)
Write speed [Fast-20(Ultra SCSI)]	11.5MByte/sec(Max.) [512MB, 1GB] 12.0MByte/sec(Max.) [2GB] 13.5MByte/sec(Max.) [4GB,8GB]
Shock resistance	10780 m/s <sup>2</sup> (1100G) (Max) [Non-operating state]
Vibration resistance	161.7 m/s <sup>2</sup> (16.5G) peak (20Hz~2000Hz) [Operating state]
ECC 4bit	4-bit error correction

**Data block length**

512Byte

**Data buffer**

512Byte FIFO (256Byte×2)

**Power supply**

DC 5.0V ± 10%

**Environmental conditions**

Operating temperature	0°C to 60°C
Operating Humidity	~85% (Max) [Non condensing]
Storage temperature	-20°C to 65°C
Storage Humidity	~95% (Max) [Non condensing]

**BUS**

Signal Line	Single-Ended Narrow SCSI
Internal terminator	Active Terminator
TERMPWR	Host supplies line
Data Bus Parity Function Support	
Bus Arbitration Function Support	
Disconnect/Resection Function support	

**Command**

SCSI-2 (CCS Rev4.B) Command Set Compatible  
SCSI-2(ANSI X3.131-1994 : Small Computer System Interface-2) Standard  
Ultra SCSI(ANSI X3.277-1996 : SCSI-3 FAST-20) Standard

**Weight**

400 g (Max.)

**Access LED : (Optional)**

We have option LED cable to connect your LED.

\*\*\*\*If you require the option, ask us before order.\*\*\*\*

[Internal circuit ]

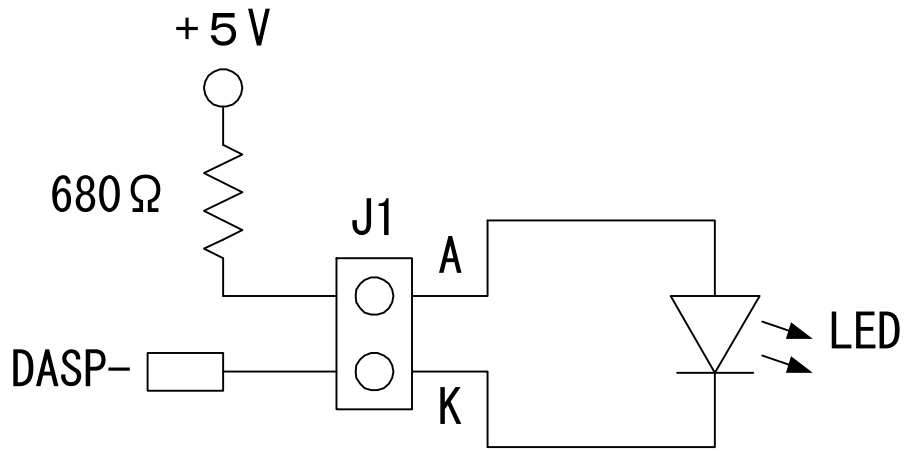

**Mechanical Specification**

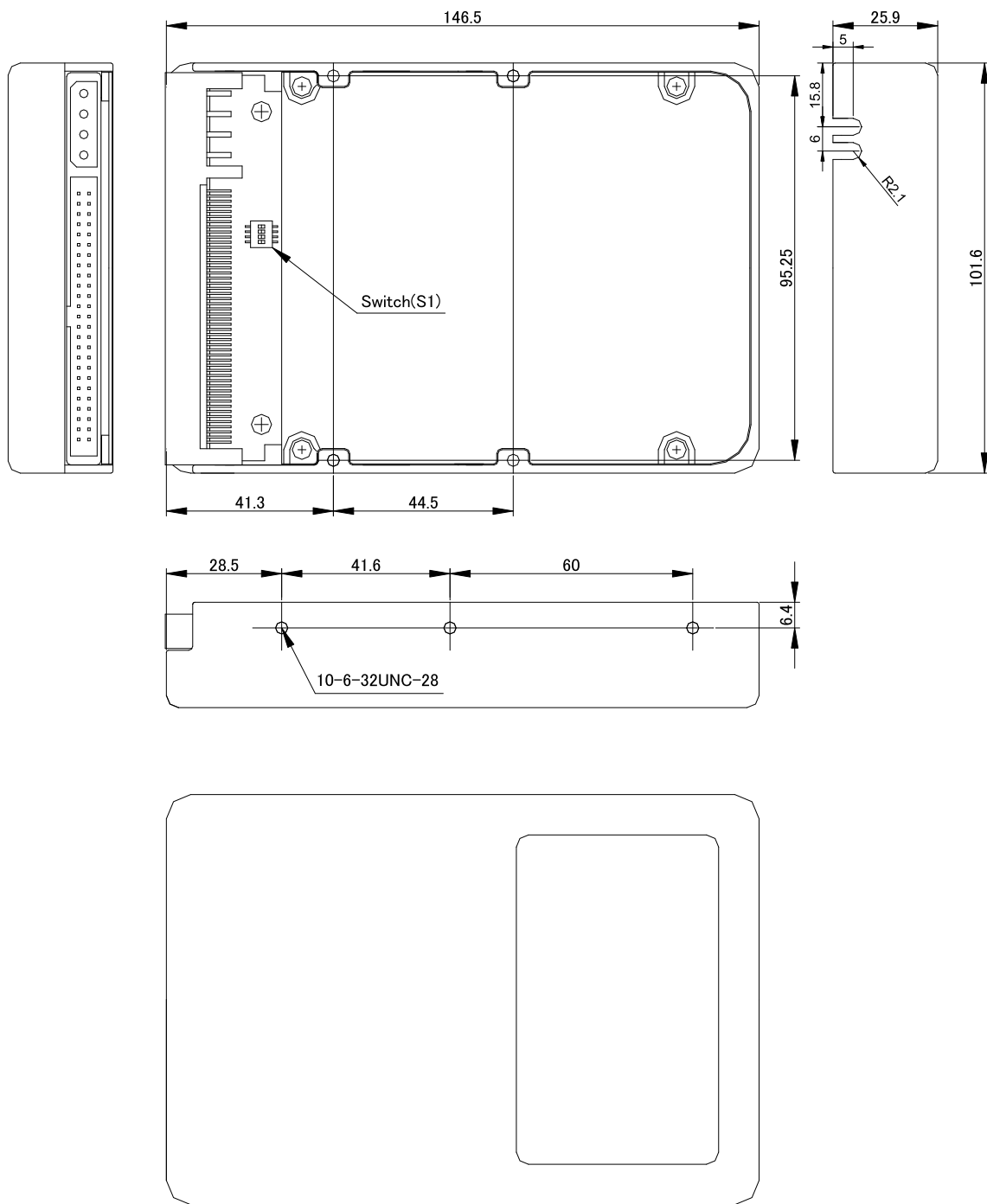

\* Not specified of allowance is +/- 0.2mm

Unit: mm

**Electric Characteristic****Maximum Ratings**

Symbol	Parameter	Value	Unit
V <sub>CC</sub>	Power Supply Voltage	-0.5 to 6.0	V
V <sub>in</sub>	Input Voltage	-0.3 to V <sub>CC</sub> +0.3	V
T <sub>stg</sub>	Storage Temperature range	-20 to 65	°C
T <sub>opr</sub>	Operating Temperature range	0 to 60	°C

**Allowable DC Operating Conditions**( Ta = 0°C~60°C, V<sub>CC</sub> = 5.0V±10% )

Symbol	Parameter	Min.	Typ.	Max.	Unit
T <sub>a</sub>	Operating Temperature	0	25	60	°C
V <sub>CC</sub>	Power Supply Voltage	4.5	5.0	5.5	V
V <sub>IH</sub>	High Level Input Voltage	2.0	-	5.5	V
V <sub>IL</sub>	Low Level Input Voltage	0	-	0.8	V
TERMPWR	Terminator Power	4.25	5.0	5.25	V

**DC Characteristics**( Ta = 0°C~60°C, V<sub>CC</sub> = 5.0V±10% )

Symbol	Parameter	Min.	Typ.	Max.	Unit
I <sub>CCI</sub>	Ready	-	60	-	mA
I <sub>CCR</sub>	Sector read mode	-	120	-	mA
I <sub>CCW</sub>	Sector write mode	-	125	-	mA
V <sub>OH</sub>	High Level Output Voltage	2.5	-	5.5	V
V <sub>OL</sub>	Low Level Output Voltage	0	-	0.5	V

## Setting Switch

Use the DIP switch to designate the SCSI-ID and terminator of a connected drive.  
In each designation, a value '0' indicates OFF and '1' indicates ON.

 in the following table shows settings at the time of shipping.

1	2	3	4	Designation	
0	0	0		SCSI-ID	SCSI-ID 0
1	0	0			SCSI-ID 1
0	1	0			SCSI-ID 2
1	1	0			SCSI-ID 3
0	0	1			SCSI-ID 4
1	0	1			SCSI-ID 5
0	1	1			SCSI-ID 6
1	1	1			SCSI-ID 7
			0	Terminator	Terminator ON
			1		Terminator OFF

**Pin assignment**

**Pin configuration**

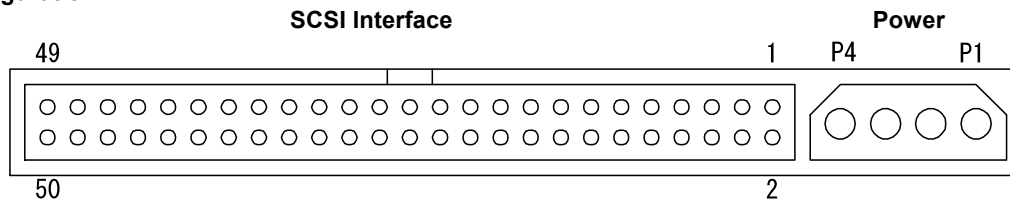

**Power s** : 4pin (5.08mm pitch)

Pin No.	Signal Name
P1	OPEN
P2	GND
P3	GND
P4	+5V

**SCSI Interface : Non-shield connector 50pin (2.54mm pitch)**

Pin No.	Signal Name	Pin No.	Signal Name
1	GND	2	-DB0
3	GND	4	-DB1
5	GND	6	-DB2
7	GND	8	-DB3
9	GND	10	-DB4
11	GND	12	-DB5
13	GND	14	-DB6
15	GND	16	-DB7
17	GND	18	-DBP
19	GND	20	GND
21	GND	22	GND
23	(OPEN)	24	(OPEN)
25	(OPEN)	26	TERMPWR
27	(OPEN)	28	(OPEN)
29	GND	30	GND
31	GND	32	-ATN
33	GND	34	GND
35	GND	36	-BSY
37	GND	38	-ACK
39	GND	40	-RST
41	GND	42	-MSG
43	GND	44	-SEL
45	GND	46	-C/D
47	GND	48	-REQ
49	GND	50	-I/O

**Signal Description**
**SCSI bus signals**

Signal Name	Dir.	Pin#	Description
-BSY	I/O	36	It is busy signal. When using the bus, it asserts. When the other target has used the bus, it is asserted.
-SEL	I/O	44	It is the selection signal. It uses when it selects the target with the initiator. It uses when reselect the initiator with the target.
-C/D	O	46	It is the control/data signal. In order to display control on the data bus or data information, although it uses. The truth is control.
-I/O	O	50	It is the input/output signal. It control direction of the data bus with the initiator. The input is control.
-MSG	O	42	It is message signal. It uses with message phase.
-REQ	O	48	It is request signal. It uses to request as a handshake of the information transfer of -ACK.
-ACK	I	38	It is the acknowledging signal. It uses to the approval with the initiator as a handshake of the information transfer of -REQ.
-ATN	I	32	It is the attention signal. The initiator is used in attention state.
-RST	I	40	It is the reset signal. Hard reset When this signal is asserted above 800ns.
-DB7-0	I/O	16,14,12,10,8,6,4,2	It is the data bus signal of 8 bit width. -DB7 is highest and -DB0 is lowest. It uses for SCSI-ID indicate too.
-DBP	I/O	18	It is odd parity bit data bus signal.
TERMPWR	I	26	It is line for terminator. It is supplied from host side.
GND	—	1,3,5,7,9,11,13,15,17,19,21,29,30,31,33,34,35,37,39,41,43,45,47,49	Grand.
OPEN	—	23,24,25,27,28	No use. It is opened state.

**Signal sources**

Bus phase	-BSY	-SEL	-C/D,-I/O,-MSG,-REQ	-ACK,-ATN	-DB7-0,-DBP
BUS FREE	None	None	None	None	None
ARBITRATION	All	Win	None	None	S-ID
SELECTION	I&T	Init	None	Init	Init
RESELECTION	I&T	Targ	Targ	Init	Targ
COMMAND	Targ	None	Targ	Init	Init
DATA IN	Targ	None	Targ	Init	Targ
DATA OUT	Targ	None	Targ	Init	Init
STATUS	Targ	None	Targ	Init	Targ
MESSAGE IN	Targ	None	Targ	Init	Targ
MESSAGE OUT	Targ	None	Targ	Init	Init
All : All of SCSI devices are used. S-ID : -DB7-0 means SCSI-ID. -DBP is the truth. I&T : It uses initiator and target both. Init : It uses initiator only. None : No use. Win : Won arbitration of SCSI device is used. Targ : Operating target device is used only.					

**SCSI Bus phase**

**BUS FREE phase**

Bus free phase is in a state where every SCSI device has not used the bus. When -BSY signal and -SEL signal both are under false, it becomes bus free. It will be bus free after reset of initial state and after SCSI device released

**ARBITRATION phase**

Arbitration phase allows that SCSI device get control SCSI bus. SCSI device asserts -BSY signal and SCSI-ID bit (Data bus) when bus free. However, when initiator does not support resection, initiator will win. The won device asserts -SEL signal, lose device will release -BSY signal and SCSI-ID bit. Then sift selection phase and reselection phase. It can omit when system component is single initiator.

**SELECTION phase**

SCSI device become initiator in arbitration phase which is selected target in selection phase. It doesn't assert -I/O signal during selection phase. Initiator set own SCSI-ID and target SCSI-ID on data bus and asserts -ATN signal. Initiator waits response from target after release -BSY signal. Target checks -SEL signal and own SCSI-ID bit is true and -BSY and I/O signal is false. Specified target asserts -BSY signal. Then sift Information transfer phases. In case of no-response from target, go process to section time out phase.

**SECTION time out**

Section time out process supports 2 kinds that is initiator asserts -RST signal or sift bus free.

**RESELECTION phase**

Reselection phase select initiator after became target device which won at arbitration phase. I/O signal is asserted in reselection phase. Won SCSI device asserts -BSY signal and -SEL signal. The device set own SCSI-ID and initiator's SCSI-ID bit on data bus. Target release -BSY signal. Initiator checks -SEL and I/O signal is true and -BSY signal reselected as false. Reselected initiator checks reselected target of SCSI-ID. Reselected initiator asserts -BSY signal. Target checks -BSY signal is true. And Target asserts -BSY signal and releases -SEL signal. Target exchange -I/O signal and data bus. Reselected initiator checks -SEL signal is false and release -BSY signal. It continues asserting till hand over SCSI bus. Then go information transfer phases. When it doesn't response from initiator, go selection time out process. Section time out process supports 2 kinds that is initiator asserts -RST signal or sift bus free.

**Information transfer phases**

With using -C/D, -I/O and -MSG signal discriminate deference information transfer phases. Target control each information transfer and phases. with using the 3 of signal. Initiator asserts -ATN signal and request message out phase. Target release -MSG, -C/D, -I/O and -BSY signal and go bus free phase. Information transfer phase uses hand shake of -REQ/ACK to control information transfer. Each -REQ/ACK of hand shake allows 1byte information transfer. -BST signal is true and -SEL signal is false during the phase.

-MSG	-C/D	-I/O	Phase name	Direction of transfer	Asynchronous	Synchronous
false	false	false	DATA OUT	Initiator → Target	○	○
false	false	true	DATA IN	Initiator ← Target	○	○
false	true	false	COMMAND	Initiator → Target	○	×
false	true	true	STATUS	Initiator ← Target	○	×
true	false	false	Reserved	—	—	—
true	false	true	Reserved	—	—	—
true	true	false	MESSAGE OUT	Initiator → Target	○	×
true	true	true	MESSAGE IN	Initiator ← Target	○	×

**COMMAND phase**

Command phase allows with target if initiator require command information. Target asserts –C/D signal and negates -I/O signal and –MSG signal for hand shake of –REQ/ACK.

**DATA IN phase**

Data in phase allows with target if require to send date from target to initiator.

**DATA OUT phase**

Data out phase allows with target if require to send date from target to initiator.

**STATUS phase**

Status phase allows with target if require to send date from target to initiator.

**MESSAGE IN phase**

Message in phase allows with target if require to send date from target to initiator.

**MESSAGE OUT phase**

Message out phase allows with target if it request from initiator to target. Target calls

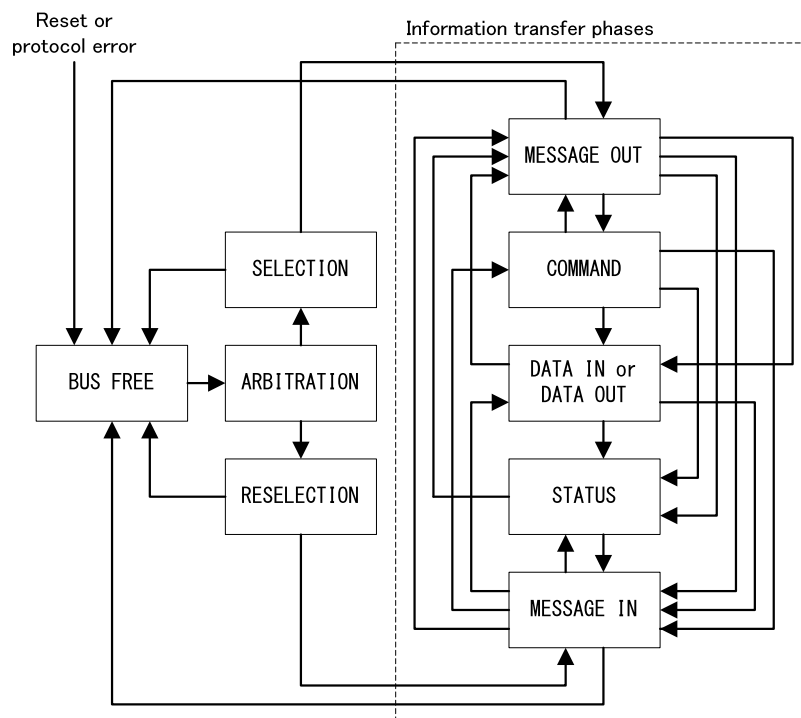
**SCSI Bus phase sequences**

## Reset characteristic

Reset sequence is in below.

### Reset Timing

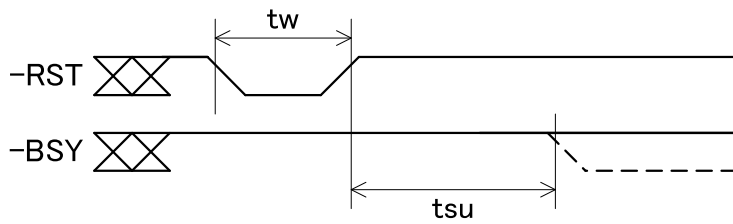

### Reset Characteristics

Parameter	Symbol	Min.	Typ.	Max.	Unit
Reset pulse width	$t_w$	800	—	—	ns
Reset setup time	$t_{su}$	—	550	—	ms
Power on reset setup time	$t_{posu}$	—	—	900	ms

## Important Notes:

- \* If reset or power off the device, all of resistor is cleared.
- \* Don't plug off device when operating.

**Remarks**

The maximum data transfer rate in the asynchronous transfer mode may be restrained by the response rate of an initiator and the length of a SCSI bus cable; the maximum obtainable data transfer rate in the synchronous transfer mode on the Single-Ended SCSI bus is limited by the length of a SCSI bus cable, the transmission characteristics of a cable, the number of linked SCSI systems, and other factors.

- All efforts have been made to improve the quality and reliability of these products, but semiconductor devices in general are prone to malfunction and failure. Purchasers of these products are responsible for designing safe systems that will not endanger human life or cause bodily injury or property damage because of malfunctions or failures of these semiconductor products. Designers are requested to check the latest specifications and use these products within their guaranteed ranges.
- These products should not be used in military, nuclear energy control, aerospace, and other special purpose applications, or in control systems for automobiles including motorcycles and bicycles, control systems for trains, ships, and transportation equipment, safeguard systems such as crime and disaster prevention systems, and medical devices including medical measurement instrument. We assume no liability for any alleged or actual damages arising from the use of this product for such purposes. Please contact one of our representatives for more detailed information.
- Restriction is imposed on the export and overseas provision of the products covered herein by the Foreign Exchange and Foreign Trade Control Law.
- The technical information herein is provided to describe the typical operations and applications of our products. No warranty of any kind is made herein with regard to intellectual property rights and other rights of our company and the third parties, nor is any license for use thereof granted herein.
- The information described herein is subject to change without notice due to technological advances and other factors.